



## Modular ice maker - Granular system Daily production up to 590 kg

Hotel	████████████████████
Restaurant	████████████████████
Fast food	████████████████████
Bar	████████████████████
Disco	████████████████████
Fish market	████████████████████
Supermarket	████████████████████
Medical & SPA	████████████████████
Industry	████████████████████

### ► Features & Plus

- Granular ice - 80-82% dry
- 1l (water) - 1kg (ice) - only Air cooled
- AISI 304 SS Scotch Brite finish
- Tropical class +43°C
- Specific volume 1 m<sup>3</sup> = 550 kg of ice
- Removable and cleanable air filter
- AISI 304 SS evaporator
- Air or water cooling system
- Easy cleanable internal rounded surfaces
- Dust-proof water basin
- RoHS Free
- Electromechanical operation
- ON-OFF rocker switch
- Rotation sensor on low speed shaft
- Automatic water charge
- Standard and special voltages
- Frame in INOX



Removable and cleanable air filter



AISI 304 SS evaporator



Dust-proof water basin



Easy cleanable internal rounded surfaces



Frame in INOX

### ► Usable Bins

- Bin 240PE
- Bin 110
- Bin 200
- Bin 350
- Bin 550V DS
- Roller Bin 100
- Double Roller Bin 100
- Double Roller Bin 500
- Double Roller Bin 1200

### ► Prod. 24h

Air temp.		Water temp.		Kg	Lbs
10° C	50° F	7° C	45° F	590	1301
21° C	70° F	15° C	60° F	510	1124



### Warranty

3 years parts & labor, 5 years on the compressor subject to limitations

### ► Certifications available for this model





Ice Flakes

**G 510**

### Modular ice maker - Granular system Daily production up to 590 kg

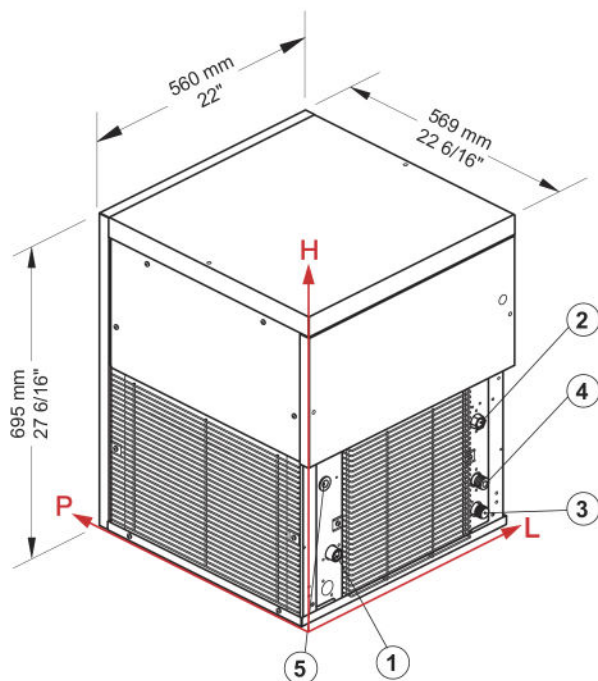

#### ► Working conditions

- Location: **Indoor**

	Min	Max
Ambient temperature	+10° C / +50° F	+43° C / 110° F
Water temperature	+3° C / +37° F	+32° C / +90° F
Voltage	-10%	+10%
Water inlet pressure	1bar (14 psi)	6bar (84 psi)

#### ► Performances

	Air temperature	Water temperature					
		7° C	45° F	15° C	60° F	21° C	70° F
	10° C	590 kg					
	50° F		1301 lbs				
	21° C			510 kg			
	70° F				1124 lbs		
	32° C					411 kg	
	90° F						906 lbs

#### ► Connections

All measures are referred to the down-left corner (L-H-Ø)

- ① Water in.: 85,5 mm / 3 6/16" - 130 mm / 5 2/16" - 3/4"
- ② Cond. water in.: 479,5 mm / 18 14/16" - 260 mm / 10 4/16" - 3/4"
- ③ Water out.: 479,5 mm / 18 14/16" - 65 mm / 2 9/16" - 24 mm / 15/16"
- ④ Cond. water out.: 479,5 mm / 18 14/16" - 130 mm / 5 2/16" - 24 mm / 15/16"
- ⑤ Electrical connections: 67,5 mm / 2 11/16" - 290 mm / 11 7/16"
- ② ④ Only for water cooling systems

#### ► Technical information

Production in 24h	510 kg / 1124 lbs	Sizes (L-P-H mm)	560 - 569 - 695
Cooling system	A - W	(L-P-H in)	22 - 22 6/16 - 27 6/16
Refrigerant	R404A - R452A	Sizes with pack (L-P-H mm)	645 - 645 - 910
Standard voltage	220-240 V ~ 50 Hz	(L-P-H in)	25 6/16 - 25 6/16 - 35 13/16
Average power consumption	1700 W	Net weight	102 kg / 225 lbs
Fuse	16 A	Gross weight	113 kg / 249 lbs
Water consumption	A: 1 l/kg - 12,0 gal/100 lbs W: 5,8 l/kg - 69,5 gal/100 lbs	Finish	AISI 304 stainless steel, scotch brite

All the technical information need to be considered at the following conditions:

- Ambient temperature +21° C
- Water temperature +15° C
- Average power consumption at +43° C (standard voltage)
- Refrigerant R404A

Models and specifications are subject to change without notice

**CANADA**  
120 de la Barre  
Boucherville, QC J4B 1K7

**US**  
334 Cornelia, St. # 272  
Plattsburgh, NY 12901

Tel.: 1 888-956-6866  
Fax: 1 877-956-6867

[www.eurodib.com](http://www.eurodib.com)  
info@eurodib.com