

ATMOVAC

VACUUM MACHINES



Made in the Netherlands

APP FUNCTIONALITY

- Define program names and labels
- Control settings
- (De)activate options and functions
- HACCP logging
- Wireless printer settings

OROSHI

Our OROSHI series is our most feature rich offering from App compatibility to HACCP compliance, these ones have it all. Our most advanced family of machines with laser welded for flawless construction. ATMOVAC's Touch control is standard equipped with Sensor control and a Bluetooth connection. Basic functionality, such as vacuum percentage and seal time, can be programmed on the machine. To be in control of all other options and functions, use the VacAssist app, available for free in the App Store and Google Play Store.

Features:

- Touch panel
- APP in 5 languages
- 20 program memory
- BT connection
- Label printer compatibility
- HACCP compliance
- Secured multi-level access
- Online programming
- Marinating
- Tenderizing
- Red meat packaging
- Sequential vacuum
- Liquid control
- Gas flush (optional)



	OROSHI16	OROSHI16D
Standard	Touch control with sensor control*, double seal, soft air, liquid control**	Touch control with sensor control*, double seal, soft air, liquid control**, 2 x sealing beams
Power	120V, 900W, 12A, 5-15P	120V, 900W, 17A, 5-20P
Chamber size	14.5" x 16.5" x 7"	18.1" x 16.5" x 7"
Seal bar	16.5"	2 x 16.5"
Pump speed	21 m ³ /h	21 m ³ /h
Machine cycle	15-35 sec	20-40 sec
Dim. (L x W x H)	21.4" x 19.6" x 18.1"	25" x 19.6" x 18.3"
Net weight	143 lbs	156 lbs
Ship dim.	24" x 22.8" x 20.4"	27.1" x 22.8" x 20"
Ship weight	161 lbs	177 lbs

*Sensor control:
The vacuum process will end as soon as the pre-set percentage has been reached.

**Liquid control:
Will prevent liquid from boiling during the vacuum process. As soon as the boiling point is detected the vacuum process stops and the bag is sealed. With no loss of moisture this protects the product, the pump and vacuum chamber.

4 CLEAR RETURNS ON INVESTMENT

- **Scale saving:** Save money on your food cost by safely handling larger quantities.
- **Food saving:** Minimize food waste.
- **Go to market:** Bring your finished products to the marketplace in a safe, traceable and easily identifiable package.
- **Sous-Vide:** Incorporate Sous-Vide cooking processes in your kitchen, saving you labor costs and enhancing the quality of your offering.

Can be installed at purchase or bought separately. Professional installation required.

OH1416-ORO16

GAS KIT - Allows for gas flush packaging.

OH1416-ORO16D



Warranty: 1 year parts and labor, 3 years parts (pumps, Teflon seal tape and gaskets are EXCLUDED from parts warranty)



Bosch pump

Powerful, reliable & maintenance friendly

All in a cost and space effective solution!

ATMOVAC

OROSHI16

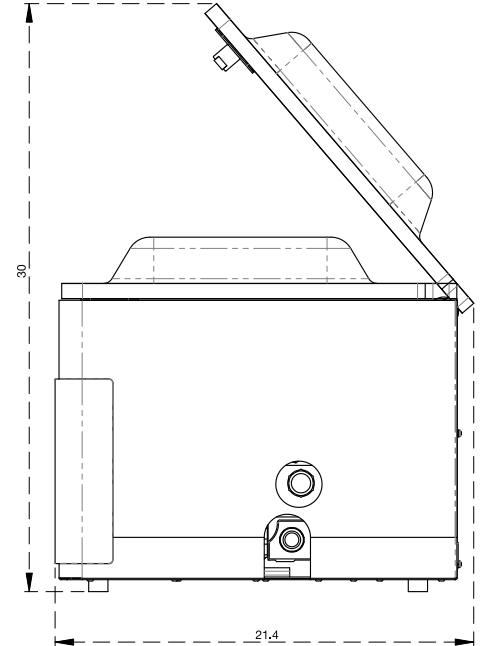
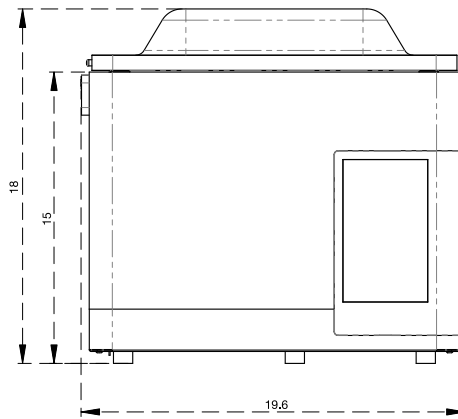
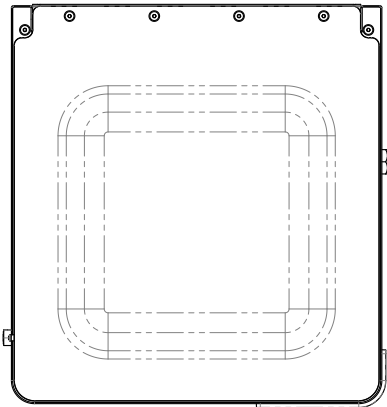

OROSHI16D

