



Toaster

Eurodib's conveyor toaster is engineered with a heavy-duty gearbox and chain drive system, making it adept at managing high-volume toasting demands. It features dual robust metal incolony heating elements for efficient heating. Adjustable controls provide operators with the flexibility to customize toasting preferences. The unit offers versatility with the option for pass-through or return operation, and its spacious opening accommodates various items like bagels and muffins.

Product Features

- Stainless steel construction
- Top and bottom metal heating elements
- Dual function energy and speed performance control
- 3 function heat control
 - Dual top and bottom element heating
 - Top element heating
 - ECO energy saving feature
- Variable speed control of the conveyor belt
- Pass through and return operation
- Removable feeder rack and crumb tray
- Removable crumb/grease tray
- Large cavity opening for bagels, muffins: 2.2"
- Non slip adjustable legs



Conveyor Toaster



SFE02710

Conveyor Toaster

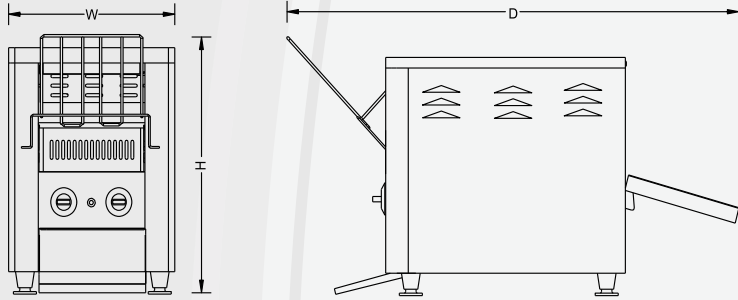
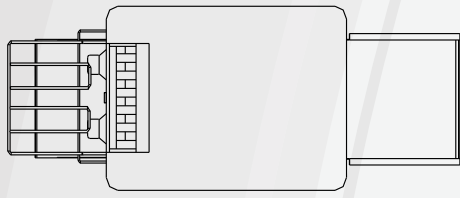

Product Code

SFE02710

Capacity/
Cooking Area

10.2" x 15.7" x 2.7"

Electrical

240V, 2600W,
10.8A, 6-15P

Product Overall Dimensions (inch)

Width
14.6

Depth
29.5

Height
15



SFE02710

■ Warranty: 1 year Parts and Labor



US 156 Lawrence Paquette, Champlain, NY 12919 | CAN 120 rue de la Barre, Boucherville, QC J4B 2X7
1 888 956 6866 | info@eurodib.com | www.eurodib.com